



CIC 200™ RECIPROCATING SAW BLADES 1/2" SHANK BI-METAL ASSORTMENT



























FEATURES:

- Bi-metal construction of high cobalt content, high speed steel and alloy steel for faster cutting and greater durability
- A variety of blades for wood and metal cutting

P/N 17713



22

			
<p>12 x 18 TPI P/N 19428</p>	<p>FOR HEAVY GAUGE METAL 18 GA TO 1/8"</p>		<p>8 82503 19428 4</p>
			
<p>12 X 6 TPI P/N 19409</p>	<p>FAST CUTTING IN WOOD OR NAIL-EMBEDDED WOOD</p>		<p>8 82503 19409 3</p>
			
<p>8 x 18 TPI P/N 19418</p>	<p>FOR HEAVY GAUGE METAL 18 GA TO 1/8"</p>	<p>8 x 10/14 TPI P/N 19411</p>	<p>FOR WOOD, PLASTIC AND METAL</p>
			
<p>6 x 6 TPI P/N 19408</p>	<p>FOR WOOD OR NAIL-EMBEDDED WOOD</p>	<p>6 x 14 TPI P/N 19414</p>	<p>FOR HEAVY GAUGE METAL 1/8" AND THICKER</p>
			
<p>4 x 24 TPI P/N 19419</p>			<p>FOR THIN METAL 18 GAUGE AND UNDER</p>
			
<p>6 x 24 TPI P/N 19420</p>	<p>FOR THIN METAL 18 GAUGE AND UNDER</p>	<p>6 x 10 TPI P/N 19410</p>	<p>FOR WOOD AND NON-FERROUS METALS</p>
			
<p>4 x 18 TPI P/N 19416</p>			<p>FOR HEAVY GAUGE METAL 18 GA TO 1/8"</p>
			
<p>6 x 18 TPI P/N 19417</p>	<p>FOR HEAVY GAUGE METAL 18 GA TO 1/8"</p>	<p>3 x 18 P/N 19426</p>	<p>FOR METAL SCROLL CUTTING</p>
			
<p>4 x 14 TPI P/N 19413</p>			<p>FOR HEAVY GAUGE METAL 1/8" AND THICKER</p>

TRAY FRONT

A26-1



CIC 200 BI-METAL HOLE SAWS 5/8" TO 2" ASSORTMENT







P/N 17712

FEATURES:

- CIC 200 hole saws cut faster and longer – saving time, money and labor
- Variable pitch tooth design

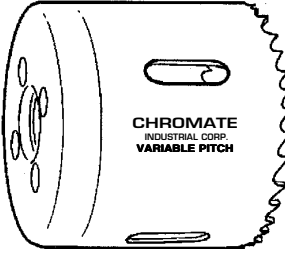
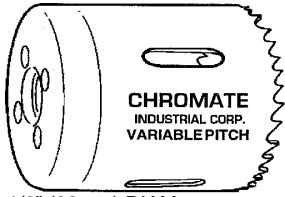
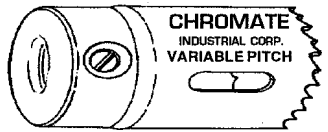
- M3 high speed steel cutting edge
- 1-3/8" depth

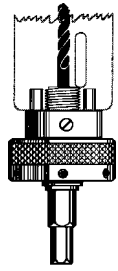
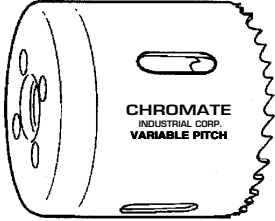
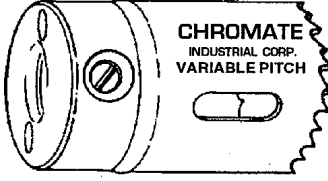
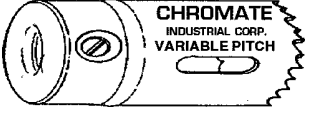
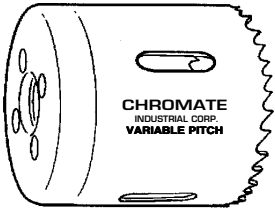
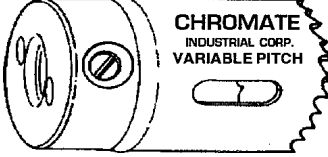
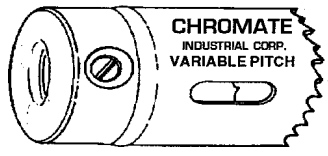
16

 <p>1/4" x 2-7/8" PILOT DRILL P/N 3994</p>  <p>3/8" HEX ARBOR P/N 1181</p>	 <p>2" (51mm) DIAM. P/N 1032</p>	 <p>1-1/2" (38mm) DIAM. P/N 1024</p>	 <p>1" (25mm) DIAM. P/N 1016</p>
 <p>1/4" x 4-5/16" PILOT DRILL P/N 3992</p>  <p>7/16" HEX ARBOR P/N 5450</p>	 <p>1-3/4" (44mm) DIAM. P/N 1028</p>	 <p>1-3/8" (35mm) DIAM. P/N 1022</p>	 <p>7/8" (22mm) DIAM. P/N 1014</p>
 <p>1-5/8" (41mm) DIAM. P/N 1026</p>	 <p>1-1/4" (32mm) DIAM. P/N 1020</p>	 <p>1-1/8" (29mm) DIAM. P/N 1018</p>	 <p>3/4" (19mm) DIAM. P/N 1012</p>
 <p>5/8" (16mm) DIAM. P/N 1010</p>			

A2962



CIC 200™ BI-METAL HOLE SAWS 2-1/8" TO 4" ASSORTMENT P/N 17714

FEATURES:

- CIC 200 hole saws cut faster and longer – saving time, money and labor
- M3 high speed steel cutting edge
- Variable pitch tooth design
- 1-3/8" depth

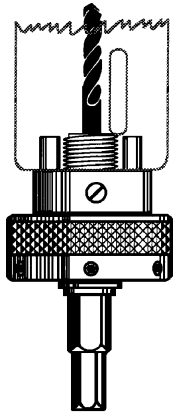

7/16"
HEX ARBOR
P/N 5450



1/4"
PILOT DRILL
P/N 3992

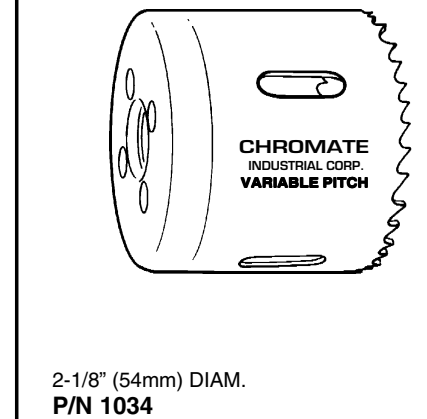
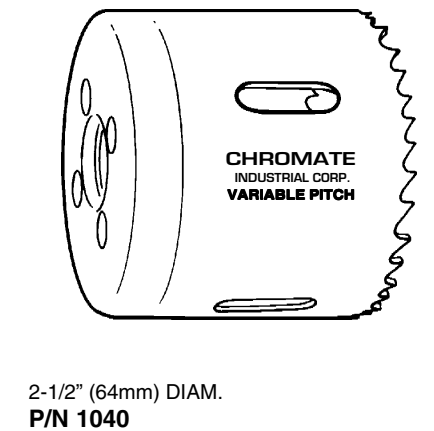
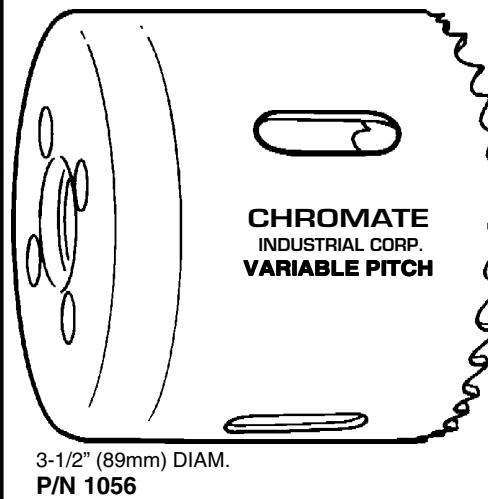
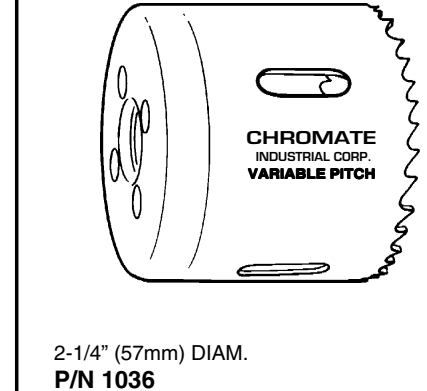
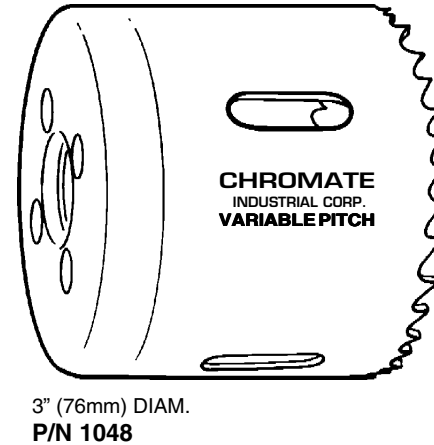
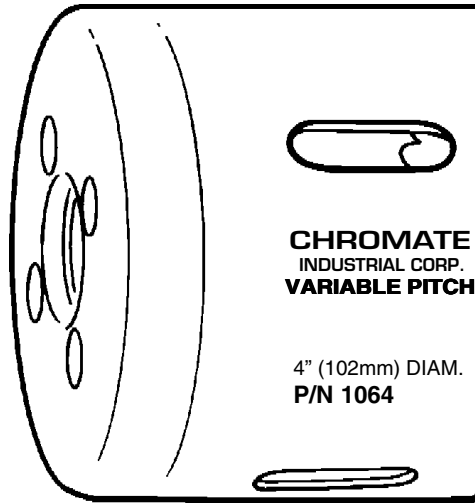

11

A263



CIC 200™ HACKSAW/ROD SAW ASSORTMENT

FEATURES:

- Bi-metal construction of high cobalt content high speed steel and alloy steel for faster cutting and greater durability
- Includes CIC 200™ tungsten carbide hacksaw and rod saw blades
- Super hard tungsten carbide particles permanently bonded to a strong alloy steel allows these blades to cut through the toughest materials

P/N 17770

36

32-26 CIC 200 BI-METAL HACKSAW BLADE
P/N 423226



24-20 CIC 200 BI-METAL HACKSAW BLADE
P/N 422420



18-14 CIC 200 BI-METAL HACKSAW BLADE
P/N 421814



12"
TUNGSTEN CARBIDE GRIT ROD SAW BLADE
P/N 22600

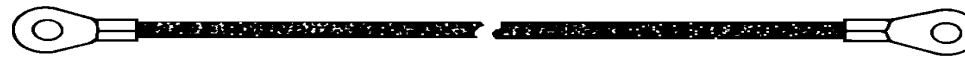

12"
TUNGSTEN CARBIDE GRIT HACKSAW BLADE
P/N 22700



10"
HALF ROUND BASTARD FILE
P/N 15532

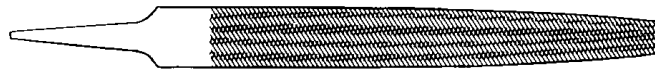

PLASTIC FILE HANDLE
P/N 15559

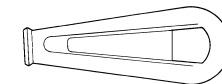

A26-5

TRAY FRONT



CIC 200™ SABRE/JIG SAW BLADE ASSORTMENT

P/N 17771



FEATURES

- Durable carbon and high-speed steel construction
- Milled teeth, set and hardened for maximum performance in metal, wood and other materials

34



2-3/4 x 24 TPI BI-METAL BLADE
P/N 19203



2-3/4 x 18 TPI BI-METAL BLADE
P/N 19202



3-5/8 x 14 TPI BI-METAL BLADE
P/N 19201

EXPANSION

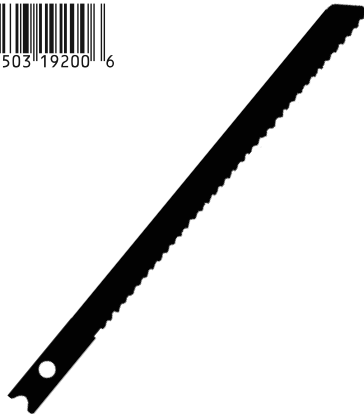

3-5/8 x 10 TPI BI-METAL BLADE
P/N 19200



3-5/8 x 6 TPI BI-METAL BLADE
P/N 19207

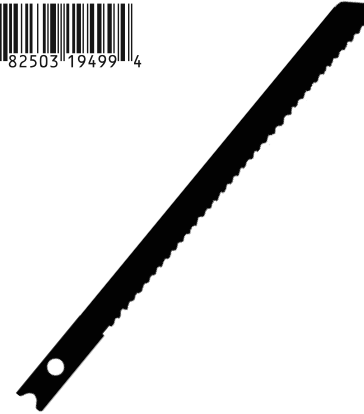

4 x 10 TPI STANDARD BLADE
P/N 19499

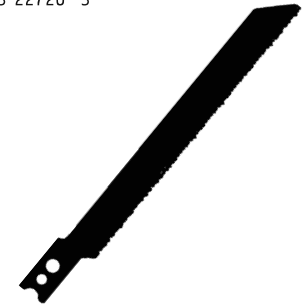

2-7/8 x 3/8 MEDIUM CARBIDE GRIT BLADE
P/N 22720

A266

TRAY FRONT



LENOX® SPEED SLOT™ BI-METAL HOLE SAWS 5/8" TO 2" ASSORTMENT











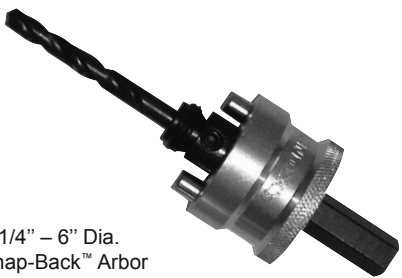



P/N 17715

FEATURES:

- Long lasting, fast cutting and versatile
- SPEED SLOT™ features a staircase design for easy plug removal

- Up to 2X life in metal cutting – Enhanced tooth geometry, a thin kerf design, and an advanced coating contribute to the efficiency of the cutting process

18

 <p>1-1/4" – 6" Dia. Snap-Back™ Arbor P/N 1095</p>	 <p>2" (50.8 mm) Dia. P/N 51723</p>	 <p>1-1/2" (38.1 mm) Dia. P/N 51716</p>	 <p>1" (25.4 mm) Dia. P/N 51707</p>
 <p>1-1/4" – 6" Dia. Snap-Back™ Arbor P/N 1094</p>	 <p>1-3/4" (44.5 mm) Dia. P/N 51720</p>	 <p>1-3/8" (34.9 mm) Dia. P/N 51714</p>	 <p>7/8" (22.2 mm) Dia. P/N 51705</p>
 <p>9/16" – 1-3/16" Dia. Snap-Back™ Arbor P/N 1093</p>	 <p>1-1/8" (28.6 mm) Dia. P/N 51709</p>	 <p>1-1/4" (31.8 mm) Dia. P/N 51711</p>	 <p>3/4" (19.1 mm) Dia. P/N 51703</p>
 <p>1/4" x 3" Pilot Drill P/N 51753</p> <p>1/4" x 4" Pilot Drill P/N 51754</p>		 <p>1-1/8" (28.6 mm) Dia. P/N 51709</p>	 <p>5/8" (15.9 mm) Dia. P/N 51701</p>

A26-7

TRAY FRONT



LENOX® SPEED SLOT™ BI-METAL HOLE SAWS 2-1/8" TO 4" ASSORTMENT

P/N 17716

FEATURES:

- Long lasting, fast cutting and versatile
- *SPEED SLOT™* features a staircase design for easy plug removal
- Up to 2X life in metal cutting – Enhanced tooth geometry, a thin kerf design, and an advanced coating contribute to the efficiency of the cutting process

12

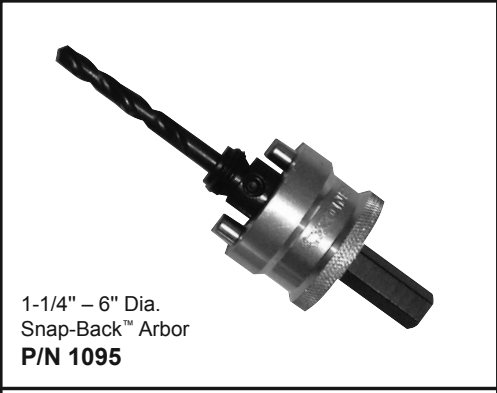

4" (101.6 mm) Dia.
P/N 51742

3" (76.2 mm) Dia.
P/N 51734

2-1/4" (57.2 mm) Dia.
P/N 51726



3-1/2" (88.9 mm) Dia.
P/N 51738

2-1/2" (63.5 mm) Dia.
P/N 51728

2-1/8" (54.0 mm) Dia.
P/N 51725

A268

TRAY FRONT



METAL CUTTING RECIPROCATING SAW BLADE ASSORTMENT

P/N 17961

FEATURES:

- Bi-metal construction of high cobalt content, high speed steel and alloy steel for faster cutting and greater durability
- A variety of blades for wood and metal cutting



19

<p>12 x 18 TPI P/N 19428</p>	 <p>FOR HEAVY GAUGE METAL 18 GA TO 1/8"</p>	 <p>8 82503 19428 4</p>
<p>12 x 14 TPI P/N 19448</p>	 <p>FOR CUTTING WOOD, NAIL-EMBEDDED WOOD AND METAL</p>	 <p>8 82503 19448 2</p>
<p>9 x 14 TPI P/N 19445</p>	 <p>FOR CUTTING WOOD, NAIL-EMBEDDED WOOD AND METAL</p>  <p>8 82503 19445 1</p>  <p>6 x 14 TPI P/N 19441 FOR CUTTING WOOD, NAIL-EMBEDDED WOOD AND METAL</p>  <p>8 82503 19441 3</p>	
<p>9" x 6 TPI DEMOLITION BLADE P/N 19453</p>	 <p>FOR CUTTING WOOD, NAIL-EMBEDDED WOOD AND METAL</p>  <p>8 82503 19453 6</p>  <p>6 x 14 TPI P/N 19414 FOR HEAVY GAUGE METAL 1/8" AND THICKER</p>  <p>8 82503 19414 7</p>	
<p>9" x 10 TPI DEMOLITION BLADE P/N 19454</p>	 <p>FOR CUTTING WOOD, NAIL-EMBEDDED WOOD AND METAL</p>  <p>8 82503 19454 3</p>  <p>6 x 18 TPI P/N 19417 FOR HEAVY GAUGE METAL 18 GA TO 1/8"</p>  <p>8 82503 19417 8</p>	
<p>8 x 18 TPI P/N 19418</p>	 <p>FOR HEAVY GAUGE METAL 18 GA TO 1/8"</p>  <p>8 82503 19418 5</p>  <p>RECIP. HOLDER P/N 30385H</p>  <p>8 82503 44930 8</p>	

A26-11

TRAY FRONT















RAZORQWIK™ CARBIDE TIPPED HOLE CUTTER ASSORTMENT

P/N 17962

FEATURES:

- Specially designed for cutting pipe, thick steel, steel plate, iron, aluminum, copper, cast iron and stainless steel up to 1" thick
- Special tungsten carbide teeth – excellent wear and heat resistance
- One piece construction – no assembly required and stable accurate drilling
- Ejector spring ejects the slug saving time
- Safety collar stop prevents over penetration for safer, faster operation

91

 <p>5/8" Carbide Tipped Hole Cutter P/N 51110</p>	 <p>11/16" Carbide Tipped Hole Cutter P/N 51111</p>	 <p>3/4" Carbide Tipped Hole Cutter P/N 51112</p>	 <p>13/16" Carbide Tipped Hole Cutter P/N 51113</p>
 <p>7/8" Carbide Tipped Hole Cutter P/N 51114</p>	 <p>15/16" Carbide Tipped Hole Cutter P/N 51115</p>	 <p>1" Carbide Tipped Hole Cutter P/N 51116</p>	 <p>1-1/16" Carbide Tipped Hole Cutter P/N 51117</p>
 <p>1-1/8" Carbide Tipped Hole Cutter P/N 51118</p>	 <p>1-1/4" Carbide Tipped Hole Cutter P/N 51120</p>	 <p>1-3/8" Carbide Tipped Hole Cutter P/N 51122</p>	 <p>1-1/2" Carbide Tipped Hole Cutter P/N 51124</p>
		 <p>3mm Hex Key P/N 64306</p>	 <p>Carbide Tipped Pilot Drill for Hole Cutters P/N 51149</p>

A26-12

TRAY FRONT



CIC 200™ SPECIALTY RECIPROCATING BLADE ASSORTMENT

FEATURES

- **Pruning** – Very aggressive blade designed for rough-in wood, very fast cutting and pruning.
- **Plunge-N-Cut** – One step blade cuts without pilot holes. Double edge design for reversible cutting. Bi-metal construction for durability.

- **Demolition** – Extra thick blades designed for the toughest work - resists bending and breaking.
- **Tungsten Carbide Grit** – Tungsten carbide grains bonded to alloy body for faster cutting and longer life. Designed for cutting abrasive materials and the hardest steels. For fiberglass, plaster, ceramic tile, soil pipe, composites, particle board, laminates, hardwood.

P/N 17973



14

9" x 5 TPI
PRUNING
P/N 19401



12" X 6 TPI
DEMOLITION BLADE
P/N 19457



9" x 6 TPI
DEMOLITION BLADE
P/N 19453



9" x 10 TPI
DEMOLITION BLADE
P/N 19454



6" x 6 TPI
RECIP BLADE PLASTER BOARD/ SHEETROCK
P/N 19477



4 x 5/8
COARSE CARB GRIT RECIP BLADE
P/N 22740



6 x 5/8
COARSE CARB GRIT RECIP BLADE
P/N 22780



A26-13

TRAY FRONT





RAZORQWIK™ STUBBY CARBIDE TIPPED HOLE CUTTER ASSORTMENT

P/N 17982

FEATURES:

- Special tungsten carbide teeth – superior wear and heat resistance cuts stainless steel and tough alloys
- One piece construction – no assembly required and assures stable accurate drilling
- Ejector spring ejects the slug saving time
- Safety collar stop prevents over penetration for safer, faster operation
- 1/4" hex shank for use in quick-change adapters
- Fast, clean cuts every time and perfect for use in battery powered drills

14

 <p>5/8" Carbide Tipped Hole Cutter P/N 51150</p>	 <p>11/16" Carbide Tipped Hole Cutter P/N 51151</p>	 <p>3/4" Carbide Tipped Hole Cutter P/N 51152</p>	 <p>13/16" Carbide Tipped Hole Cutter P/N 51153</p>
 <p>7/8" Carbide Tipped Hole Cutter P/N 51154</p>	 <p>15/16" Carbide Tipped Hole Cutter P/N 51155</p>	 <p>1" Carbide Tipped Hole Cutter P/N 51156</p>	 <p>1-1/16" Carbide Tipped Hole Cutter P/N 51157</p>
 <p>1-1/8" Carbide Tipped Hole Cutter P/N 51158</p>	 <p>1-1/4" Carbide Tipped Hole Cutter P/N 51160</p>	 <p>1-3/8" Carbide Tipped Hole Cutter P/N 51162</p>	 <p>2.5mm Hex Key P/N 64305</p>

TRAY FRONT

A26-15



DIAMOND HOLE CUTTERS, 3/4" – 2-1/4"

FEATURES

- Sizes: 3/4" to 2-1/4"
- Range of applications from hard tile and stone to cement board and fiberglass
- Typical users: plumbers, tilers, builders, joiners and MRO

P/N 17072



13

 <p>DIAMOND HOLE CUTTER SIZE: 3/4" P/N 51770</p>	 <p>DIAMOND HOLE CUTTER SIZE: 1-1/4" P/N 51773</p>	 <p>DIAMOND HOLE CUTTER SIZE: 1-3/4" P/N 51776</p>	 <p>ARBOR 3/4" TO 1-1/8" P/N 51785</p>
 <p>DIAMOND HOLE CUTTER SIZE: 7/8" P/N 51771</p>	 <p>DIAMOND HOLE CUTTER SIZE: 1-3/8" P/N 51774</p>	 <p>DIAMOND HOLE CUTTER SIZE: 2" P/N 51777</p>	 <p>ARBOR 1-1/4" TO 4" P/N 51786</p>
 <p>DIAMOND HOLE CUTTER SIZE: 1-1/8" P/N 51772</p>	 <p>DIAMOND HOLE CUTTER SIZE: 1-1/2" P/N 51775</p>	 <p>DIAMOND HOLE CUTTER SIZE: 2-1/4" P/N 51778</p>	 <p>PILOT DRILL P/N 51787</p>

A26-16

TRAY FRONT



DIAMOND HOLE CUTTERS, 2-1/2" – 4"

FEATURES

- Sizes: 2-1/2" to 4"
- Range of applications from hard tile and stone to cement board and fiberglass
- Typical users: plumbers, tilers, builders, joiners and MRO

P/N 17073



0



DIAMOND HOLE CUTTER
SIZE: 2-1/2"
P/N 51779



DIAMOND HOLE CUTTER
SIZE: 3-1/4"
P/N 51781



DIAMOND HOLE CUTTER
SIZE: 3-1/2"
P/N 51783



ARBOR
1-1/4" TO 4"
P/N 51786



DIAMOND HOLE CUTTER
SIZE: 3"
P/N 51780



DIAMOND HOLE CUTTER
SIZE: 3-11/32"
P/N 51782



DIAMOND HOLE CUTTER
SIZE: 4"
P/N 51784



PILOT DRILL
P/N 51787

A26-17

TRAY FRONT



SHEET METAL HOLE CUTTERS/FRACTIONAL





















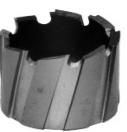

FEATURES:

- Thirteen sizes: 5/16" to 1-1/2"
- Make clean accurate burr-free holes fast!
- Use in sheet metal, plate, tube stock and plastic up to 1/2" thick (7/8" to 1-1/2"); up to 1/4" thick (5/16" to 3/4")
- Made from hardened M2 H.S.S. and precision ground to exacting specifications.
- Patented tooth geometry.

P/N 17686



24

 <p>5/16" Sheet Metal Hole Cutter P/N 51800</p>	 <p>9/16" Sheet Metal Hole Cutter P/N 51804</p>	 <p>1" Sheet Metal Hole Cutter P/N 51814</p>	 <p>1-1/2" Sheet Metal Hole Cutter P/N 51818</p>	 <p>Spacer Washer P/N 51810</p>	 <p>5/16" to 3/4" Arbor P/N 51807</p>
 <p>3/8" Sheet Metal Hole Cutter P/N 51801</p>	 <p>5/8" Sheet Metal Hole Cutter P/N 51805</p>	 <p>1-1/8" Sheet Metal Hole Cutter P/N 51815</p>	 <p>Pilot Pin for 5/16" to 3/4" Arbor P/N 51808</p>	 <p>Hex Washer P/N 51821</p>	 <p>7/8" to 1-1/2" Arbor P/N 51819</p>
 <p>7/16" Sheet Metal Hole Cutter P/N 51802</p>	 <p>3/4" Sheet Metal Hole Cutter P/N 51806</p>	 <p>1-1/4" Sheet Metal Hole Cutter P/N 51816</p>	 <p>Pilot Pin for 7/8" to 1-1/2" Arbor P/N 51820</p>	 <p>1/8 Hex Key P/N 51811</p>	 <p>Center Punch P/N 51812</p>
 <p>1/2" Sheet Metal Hole Cutter P/N 51803</p>	 <p>7/8" Sheet Metal Hole Cutter P/N 51813</p>	 <p>1-3/8" Sheet Metal Hole Cutter P/N 51817</p>	 <p>Stop Washer P/N 51809</p>	 <p>5/32 Hex Key P/N 44202</p>	<p>EXPANSION</p>

A26-18

TRAY FRONT





























BI-METAL RECIPROCATING SAW BLADES METAL CUTTING ASSORTMENT

P/N 17660



13

<p>12" x 18 TPI P/N 19428</p>  		
<p>12" x 10 TPI DEMOLITION BLADE P/N 19458</p>  		
<p>9" x 14 TPI P/N 19429</p>  <p>CHROMATE INDUSTRIAL CORP.</p> <p><small>P/N 19429 MADE IN U.S.A. 9" x 14 TPI BI-METAL FOR HEAVY GAUGE METAL 1/8" AND THICKER</small></p> 	<p>8" x 18 TPI P/N 19418</p>  	
<p>6" x 5/8 TPI DEMOLITION BLADE P/N 19455</p>  	<p>6-10" x 14 TPI P/N 19405</p>  	<p>6" x 14 TPI P/N 19414</p>  
<p>6" x 18 TPI P/N 19417</p>  	<p>6" x 24 TPI P/N 19420</p>  	<p>4" x 14 TPI P/N 19413</p>  
<p>4" x 18 TPI P/N 19416</p>  	<p>4" x 24 TPI P/N 19419</p>  	<p>3" x 18 TPI P/N 19426</p>  

A26-19

TRAY FRONT



















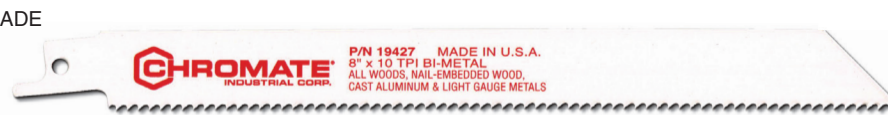



WOOD CUTTING RECIPROCATING SAW BLADE ASSORTMENT

P/N 17661



10

<p>12" x 6 TPI DEMOLITION BLADE P/N 19457</p>		
<p>12" X 6 TPI BI-METAL RECIP BLADE P/N 19409</p>		
	 <p>9" X 5 TPI PRUNING BLADE P/N 19401</p>	 <p>6" x 6 TPI BI-METAL RECIP BLADE P/N 19408</p> 
<p>8" x 10 TPI BI-METAL RECIP BLADE P/N 19427</p>	 <p>P/N 19427 MADE IN U.S.A. 8" x 10 TPI BI-METAL FAST CUTTING IN WOOD OR CAST ALUMINUM & LIGHT GAUGE METALS</p> 	<p>6" x 6 TPI RECIP BLADE PLASTER BOARD/ SHEETROCK P/N 19477</p>  
	 <p>9" x 6 TPI BI-METAL RECIP BLADE P/N 19424</p>	<p>6" x 10 TPI BI-METAL RECIP BLADE P/N 19410</p>  
<p>8" x 10/14 TPI BI-METAL RECIP BLADE P/N 19411</p>	 	 <p>RECIP. HOLDER P/N 30385H</p> 

A26-20

TRAY FRONT



STUD/METAL CUTTING RECIPROCATING SAW BLADE ASSORTMENT

P/N 17662



10

12" x 10 TPI
P/N 19423



9" x 10 TPI
P/N 19422



6" x 10 TPI
P/N 19421



12" x 14 TPI
P/N 19448



9" x 14 TPI
P/N 19445



6" x 14 TPI
P/N 19441



9" x 6 TPI
DEMOLITION BLADE
P/N 19453



6" x 5/8, COARSE CARBIDE GRIT BLADE
P/N 22780



9" x 10 TPI
DEMOLITION BLADE
P/N 19454



4" x 5/8, COARSE CARBIDE GRIT BLADE
P/N 22740



A26-21

TRAY FRONT